

M LEVELO



Levelo

**Portable 5000mAh 3 In 1
Cardholder Power Bank**

SKU: LVL-ONYX-5PB

Table of Contents

Overview	2
Specifications	2
Schematic View	2
Features	3
Operation Instructions	3
Indicator Light Guide	4
RFID Protection	4
Safety Instructions	4
Warnings	5
Warranty	6
Contact Us	6

Overview

Thank you for purchasing this power bank. It is designed to power tablets, phones, earbuds, and various types of smartphones, allowing you to stay connected and enjoy the outdoors. To ensure optimal performance and safe usage, please read this manual thoroughly before using the product.

Specifications

Capacity	5000mAh /19.25Wh
Type-C Input	5V / 2.1A (10.5W)
Type-C Output	5V / 2.4A (12W)
Charging Cable Length	165mm
Card Holder	5 Cards Slot (MAX)
Material	ABS + Aluminium Alloy
Product Size	17x70x104mm

Schematic View

1. Card slot
2. Card slot slider
3. Lanyard hole
4. Type-C Charging port
5. Ring-shaped LED power indicator light
6. Power Button
7. Lanyard charging cable

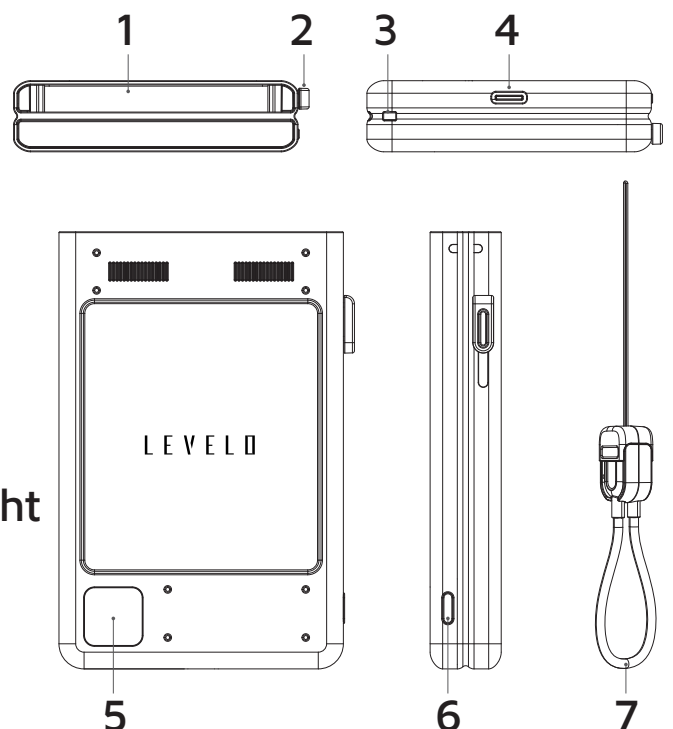

Features

1. Provides ample power to charge your devices on the go.
2. Protects your cards from unauthorized scanning and potential theft.
3. Shows the remaining battery level with a stylish ring-shaped LED light.
4. Delivers fast 12W output for efficient device charging.
5. Stores up to 5 cards securely.
6. Ensures durability and a sleek finish with anodized metal casing.
7. Features a soft, rounded button for easy, comfortable operation.
8. Allows for convenient one-handed use with automatic card ejection.
9. Comes with a lanyard charging cable for easy portability and charging.

Operation Instructions

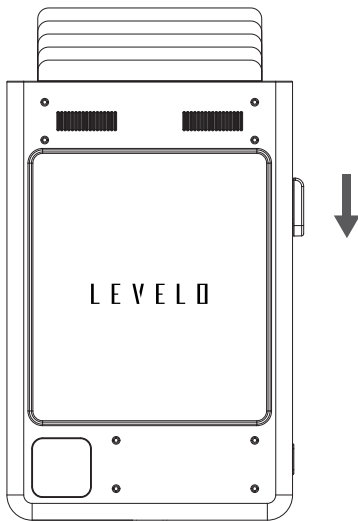

Press the button downward,
and the cards will pop out.

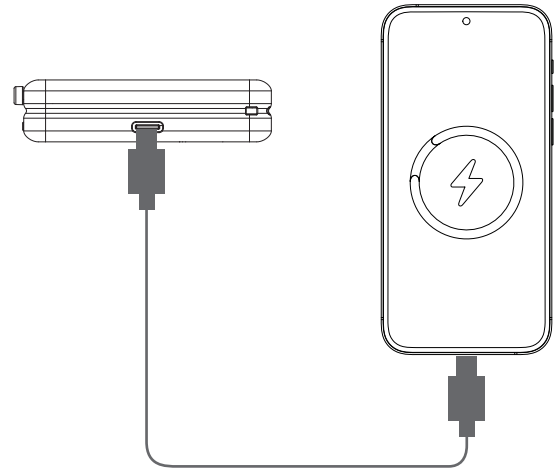

Type-C Cable Connection
(Charging other devices)

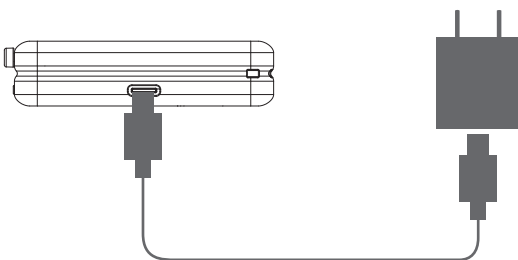

Type-C Cable Connection
(Charging the power bank)

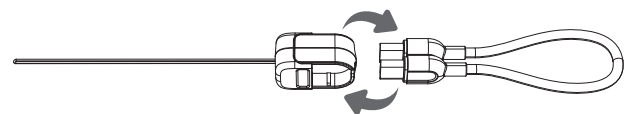

Removable Lanyard Charging Cable
(Can be removed and stored)

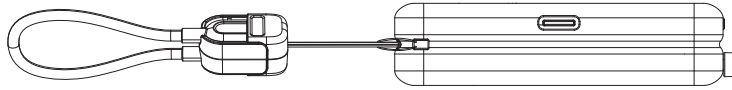

Pass the lanyard through the designated hole and secure it to the power bank.

Indicator Light Guide

Indicator Status	Battery Level
● ● ● ●	75 to 100 %
● ● ● ●	50 to 75 %
● ● ● ●	25 to 50 %
● ● ● ●	5 to 25 %
● ● ● ●	Less than 5 %

RFID Protection

Credit cards, passports, and IDs often contain RFID chips that store your personal information. This RFID-blocking wallet is equipped with an aluminum layer that blocks the electromagnetic signals emitted by these items, creating a protective barrier to prevent unauthorized scanning.

Safety Instructions

1. Keep away from children, infants, and pets.
2. Use a compatible cable for your mobile phone and digital devices.
3. Slight heating may occur during charging and discharging, which is normal.
4. Store the power bank in a dry, cool place when not in use. If unused for an extended period, ensure it is fully charged at least once every 3 months.

5. Use the cable included with the power bank for charging.
6. Keep metal objects or sharp items away from the power bank to avoid scratches or damage.
7. To prevent the cards and product from bending, avoid placing the power bank in the back pocket of your pants.
8. Never attempt to open or disassemble the card holder charger, and avoid exposing it to heavy pressure or severe drops.
9. While the device can charge in high temperatures, avoid prolonged exposure to direct sunlight. The maximum operating temperature is 45°C (113°F).

Warnings

1. Do not attempt to open or dismantle the product.
2. Do not expose the power bank to open flames or extreme heat.
3. Do not apply pressure to the power bank or stand on it.
4. Keep the power bank out of reach of children.
5. Do not leave the product in a closed car for extended periods.
6. Do not insert more than five cards into the cardholder.

Danger: If the device begins to swell or expand, stop using it immediately, contact a local disposal and recycling center, and dispose of the product according to local regulations regarding the disposal of electrical appliances.

Note: This product should not be disposed with household waste, and therefore should be sent to a local recycling center dedicated for safe disposal.

Warranty

Products procured directly from the **Levelo** website or physical store comes with a 24-month warranty. **Levelo** products purchased from any of our authorized dealers are guaranteed with a one-year warranty. If you wish to extend this warranty, you'll need to go to our website at **<https://levelobrand.com/warranty>** and fill out the necessary form, making sure to include your personal information and a photo of the product. After your request has been evaluated and accepted, we'll send you an email notification to affirm the extension of your product's warranty.

For more info, please check:

Website: **<https://www.levelobrand.com/warranty>**

Contact Us

If you have any questions about this Privacy Policy, please contact us at: **Info@levelobrand.com**

Website: **<https://www.levelobrand.com/>**

Email: **Info@levelobrand.com**

Instagram: **[levelobrand](#)**

Facebook: **[levelobrand](#)**