

M LEVELD



Levelo

**OSAKA Portable 10000mAh
Power Bank**

SKU: LVL-OSAKA-PB10K

Table of Contents

Schematic View	2
Specifications	2
Instructions for Use	3
Precautions	3
Troubleshooting	4
Disposal	5
Warranty	5
Contact Us	5

Before using the product, please carefully read this User Manual to guarantee correct usage and keep it secure for future reference.

Schematic View

1. Power Button and Fan Control Switch
2. Type-C Interface
3. Lightning Interface
4. Magnetic Wireless Charging Area

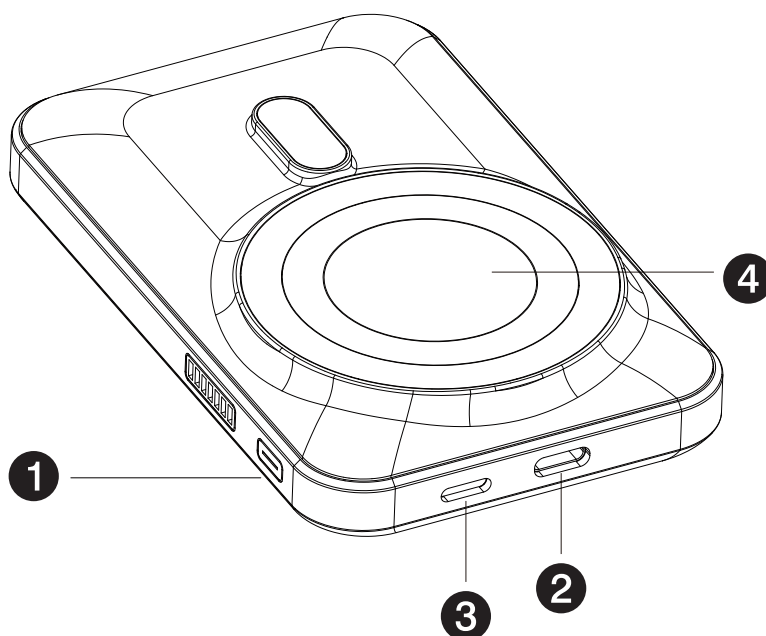

Specifications

Capacity	10000mAh/ 3.85V/ 38.5Wh
Total Output	5V/2A
Wireless Output	5W, 7.5W, 15W
Input	12V/1.5A

Type-C Output	7.5V, 2A/ 5V, 2A/ 9V, 2.22A/12V, 1.25A
Fan Speed	100000RPM
Material	Plastic Rubber Finish
Environment Temperature	0 to 40°C
Certifications	CCC,UL,CE,FCC,ROHS, PSE
Standard	GB/T35590-2017

Instructions for Use

1. The Type-C input port is designed for connecting and storing electricity in the product. Utilize both Type-C and wireless charging methods to power mobile devices.
2. Power on the power bank by pressing the power switch. If using wireless charging, the wireless indicator light will illuminate.
3. To halt the fan's rotation during magnetic suction wireless charging, press and hold the button. The charging function will continue to operate normally.
4. To fully power off the power bank, double-click the power button. The device will shut down within 3 seconds, ceasing all operations.

Precautions

1. For optimal performance and extended service life, please fully charge and discharge the product during its first use.
2. Carefully read all instructions before using the product.
3. Do not disassemble the product as this will void the warranty. Keep

it out of reach of children, infants, and pets.

4. Avoid dropping the power bank or subjecting it to impacts.

5. Do not expose the power bank to high temperatures, as this can lead to a fire hazard.

6. Avoid leaving the power bank in a car on hot days.

7. Do not expose the product to water.

Danger: Never immerse the power bank in water.

8. Avoid operating the device with wet hands.

9. Do not attempt to penetrate, disassemble, or repair the device on your own.

10. Never leave the product unattended while it is charging.

11. Do not operate the device in enclosed or poorly ventilated areas, such as under blankets.

12. Discontinue use and consult a service center immediately if the product has been impacted, dropped, exposed to water, or is functioning abnormally.

Troubleshooting

Problem	Possible Cause	Solution
The charging process for the power bank is lengthy.	1. The charging time is inadequate. 2. Either the charger or the product is malfunctioning.	1. Fully charge the power bank. Consult with distributors or after-sales service. 2. Contact an authorized service center.
The LED display does not activate.	1. There is no remaining power. 2. The power button or indicator light is malfunctioning. 3. The product has suffered a power failure.	1. Recharge the product. 2. Contact an authorized service center.
The power bank fails to show the remaining battery level.	The product's power reserves are completely depleted.	Recharge the product.
Despite not being completely discharged, the power bank abruptly stops working and does not indicate power when connected to an electrical supply.	External short-circuiting or excessive loading has activated the product's automatic protection mechanism.	Recharge the product to activate it.

Disposal

This product must not be disposed of as unsorted household waste. It is important to separate such waste for proper treatment and recycling, in compliance with local waste management regulations.

Warranty

Products procured directly from the **Levelo** website or physical store comes with a 24-month warranty.

Levelo products purchased from any of our authorized dealers are guaranteed with a one-year warranty. If you wish to extend this warranty, you'll need to go to our website at **<https://levelobrand.com/warranty>** and fill out the necessary form, making sure to include your personal information and a photo of the product. After your request has been evaluated and accepted, we'll send you an email notification to affirm the extension of your product's warranty.

For more info, please check:
<https://levelobrand.com/warranty>

Contact Us

If you have any questions about this Privacy Policy, please contact us at: **info@levelobrand.com**

Website: **<https://levelobrand.com/>**

Email: **info@levelobrand.com**

Instagram: **levelobrand**

Facebook: **levelobrand**